



RIMSA
PentaLed 12

PentaLed 12

THE ORIGINAL

PENTALED THE FIRST MEDICAL LED LAMP IN THE WORLD



RIMSA QUALITY LIGHT

A quality light helps doctors and surgeons in the operating theatre, this is related to the need to guarantee the reliability of the visual information perceived by the surgeons.

This is why Rimsa has always developed new products, paying great attention to the technological avant-garde.

RIMSA has been the first company in the world to design the LED scialytic lamp (patent registered).

Now, as then, Rimsa engineers are constantly searching for innovative solutions to improve the product performance and it is thanks to the experience gained over time that Rimsa is proud to present the family "little": PENTALED12.

"Little" only identifies the last-conceived lamp, in fact its compact dimensions and extremely handy structure are permeated by the strong determination of Rimsa heart, a synonym of high technology, quality and performance ever since.

PENTALED12 completes an already wide line of Rimsa Led lamps and can meet the needs of a surgery and diagnostic environment.

PENTALED12 is different from the previous versions thanks to its very new ergonomic design, two handy side handles assure extremely easy positioning and handling, and the flat reflector allows to minimize overall dimensions.

The ultra-light structure, the high technology and the compliance with the norm IEC 60601-2-41 make PENTALED12 suitable for:

- surgeries
- first aid station
- intensive care
- recovery room
- all the other diagnostic specializations.

Despite PENTALED12 small dimensions, we must not forget that Rimsa heart, a synonym of experience and quality for over 70 years, beats in it.

The advanced technology distinguishing this lamp is the result of a proved experience acknowledged all over the world; Rimsa was the first, in 2002, to supply an operating theatre with Led light.

This product represents a perfect union of technological developments, an innovative design and the Italian typical quality.





WHITE LIGHT

The nature has always inspired every man discovery. The sun is the preeminently source of light; its rays have a monochromatic light emission. It means that every ray has got an identical chromaticity. According to this consideration, RIMSA has adopted the principle of emission of monochromatic light, to avoid any change of temperature of colour (°K) and colour shade on the operating field. In that case the interposition of the surgeon head or hands between the lamp and the patient doesn't interfere at all on the quality and above all on the colour temperature of the light on the lighted zone. Furthermore the Colour Rendering Index (CRI) doesn't undergo any alteration of value.

RIMSA, inspired by nature, has chosen the 5,000°K colour temperature, a white light similar to sunlight at Zenith for its Led lamps.



12 EXCELLENT REASONS TO CHOOSE PENTALED 12: JUST TWELVE LEDS FOR MORE THAN 50.000 LUX. THE PARABOLA OPTIMIZES THE LIGHT FLOW OF THE LEDS INCREASING THE EFFICIENCY.

- 1 "INDIRECT" LIGHT – Indirect light means reflected light. On the basis of the physical principle of reflection the rays of light emitted by the LED are reflected by an ellipse punctiformly on the operating field.
- 2 WHITE LIGHT – to prevent the light from resolving into several colors in the lit area.
- 3 COLD LIGHT – lower number of LEDs, lower temperature generated for the doctor and patient's comfort.
- 4 LONGEVITY: the low power supply current and the excellent management of the heat dispersed by the aluminum dome allow the LED a 50,000 hours lifetime.
- 5 DOES NOT DAZZLE: the parabola directs all the light rays towards the area to be lit, thus preventing part of them from disperse and cause troublesome dazzling for the doctor and the patient
- 6 ROUND LIGHT: the round-shaped reflector allows to light the work area uniformly and it does not hinder the doctor's view
- 7 EASY TO MOVE: the side opposite handles allow to direct the light from every position, both frontally and laterally
- 8 HANDLE: automatic clutch, can be sterilized in autoclave
- 9 "PATENT" PRE-STRESSED SPRING ARM: pre-stressed spring balancing has been engineered to provide lightness of movement and positioning stability. The charge can be adjusted in time by a special mechanism
- 10 MOVEMENT: the spring arm has a vertical travel of 94 cm
- 11 ECOLOGICAL: the structure is made of steel while the dome of anodized aluminum. 85% of it is made of recyclable materials. The package, studied on purpose to protect the product against accidental collisions, is made of recyclable cardboard and does not require any particular disposal procedures.
- 12 SAVING: very low energy consumption, 2/3 lower than a conventional halogen system

VERY HIGH QUALITY DEVICE



LED LIGHT

The many undisputed advantages of Led technology are the reason for its fast development in all sectors, including the medical one. Now, as 8 years ago, Rimsa was ahead of its time designing a Led lamp for surgery and diagnostic use.

PENTAL12, 5.000K bright and cold light reproduces colours faithfully, assuring an excellent definition of details, a very important requisite for the different surgery and first aid specialities.

INDIRECT LIGHT

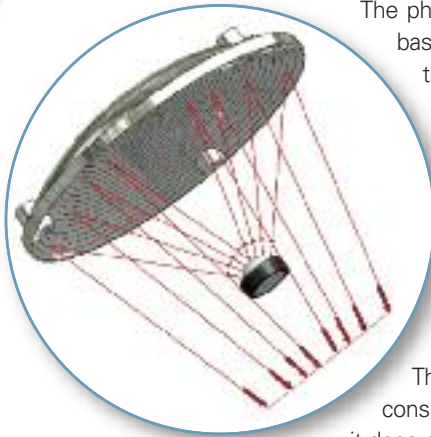

The physical principle of reflection is the base of Rimsa lamps and is applied through a system of ellipses.

They reflect the light rays issued by the Leds on the area to be lit, thus obtaining a high light intensity with a reduced number of Leds: over 50,000 lux at a distance of 1 metre with just 12 Leds.

The indirect light has considerable advantages:

- it does not dazzle
- it does not strain the eyes and favours concentration
- it meets all the visual needs in the diagnostic and minor surgery sphere.



ERGONOMIC



The circular reflector, designed to light up the work area thoroughly and suppress all the shadows, is equipped with handy side handles to facilitate positioning. The lighting body, ultra-flat in order to not disturb the operator, is equipped with ultra-resistant polycarbonate screen which guarantees protection against possible accidental collisions. PENTAL12 can be easily positioned thanks to its rotation on 4 axis:

- The structure has a side full-circle handling without any stops
- The arm moves vertically thanks to a spring-compensated balancing system
- The reflector can be rotated on the vertical and horizontal axis.

STERILIZABLE HANDLE

Movements are possible thanks to the sterilizable handle.

The ergonomic design guarantees a high handling and the versions available allow use in any surgery or laboratory.



ADJUSTABLE LIGHT INTENSITY

The lower part of the reflector incorporates, besides the switch, a digital control to adjust the light with visual signal of the intensity set.

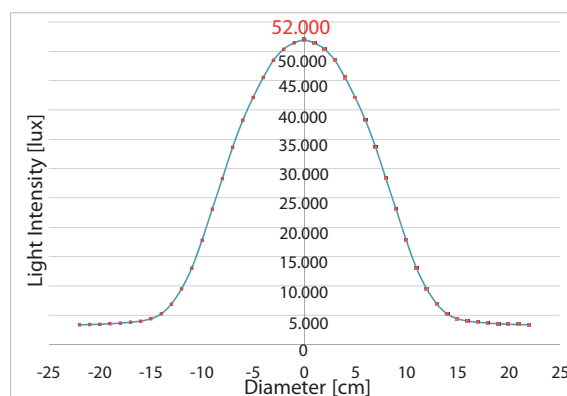

VERSATILE

"PENTALED12" characteristics make it a unique lamp. The light intensity (over 50,000 lux at a distance of 1 m) and the technical performance suit a lamp for precision operations, in intensive care, recovery room and first aid station; its handy and non-bulky structure makes it suitable for diagnostic use, pre-operating theatres and test laboratories as well.

PENTALED 12 MOBILE VERSION

The main feature of the mobile version PentaLED 12 is the great ease with which it can be positioned.

The base is mounted on castors so that the lamp can be easily moved to various surgeries.

The anti-static castors are equipped with brakes to ensure maximum stability.





PENTALED 12 CEILING VERSION

The ceiling-mounted version of the PentaLED 12 is suitable for operating theatres and surgeries of reduced dimensions or when the mobile version would be an obstacle in the presence of drip stands or medical-equipment trolleys.





PENTALED 12+12

The PentaLED 12+12 model is recommended for micro-surgery operations carried out by a team which might cause more shadows in the operating area.





PENTALED 12 WALL VERSION

The wall-mounted version of the PentaLED 12 is a valid alternative to the mobile and ceiling-mounted versions, and is recommended for operating theatres and surgeries of reduced dimensions where space saving is required. The lamp can be folded back against the wall when not in use. The wall-mounted version is also recommended when one lamp needs to be shared between two beds (for example, in emergency rooms, recovery rooms, re-animation).



Technical Data	Pentaled 12	
----------------	---------------------------------------------------------	--

PERFORMANCES

light intensity at 1 m distance (Ec)	Lux	50.000
Colour Temperature	°K	5.000
Colour Rendering Index (CRI)	Ra	90
Light field diameter where the illuminance reaches 50% of Ec (d50)	mm	85
Light field diameter where the illuminance reaches 10% of Ec (d10)	mm	140
Dept of illumination IEC 60601-2-41- (L1+L2) at 20% of Ec	cm	150 (30÷180)
Total radiated energy Ee where illuminance reaches max level	W/m ²	119
Ratio between radiated energy Ee, and illuminance Ec	mW/m ² .lx	2,38
Radiated UV energy whit wavelight less than 400 nm	W/m ²	0,001

ELECTRICAL DATA

Power transformer a.c.	V	100 - 230
Frequency	Hz	50 / 60
Electrical absorption	VA	40
Luminous source	Led	no. 12
Average led life	hours	50.000
Control of the illuminance	%	50÷100

GENERAL DATA

Mininum height of the room (only for ceiling version)	cm	220
Directive		93/42 CEE
Norms		IEC 60601-2-41
Classification of product (medical device)		Class I

DIMENSIONS

Weight (mobile, ceiling, wall, double)	Kg	18 - 13 - 12 - 20
----------------------------------------	----	-------------------

OPTIONAL

Battery group whit automatic charger		On demand
--------------------------------------	--	-----------

PENTALED 12 CEILING

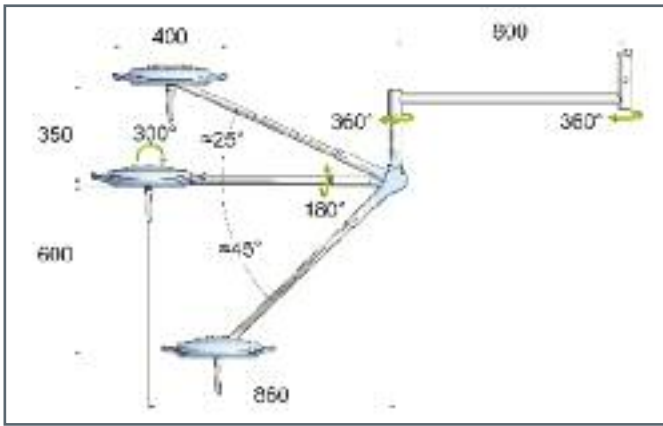

PENTALED 12 MOBILE

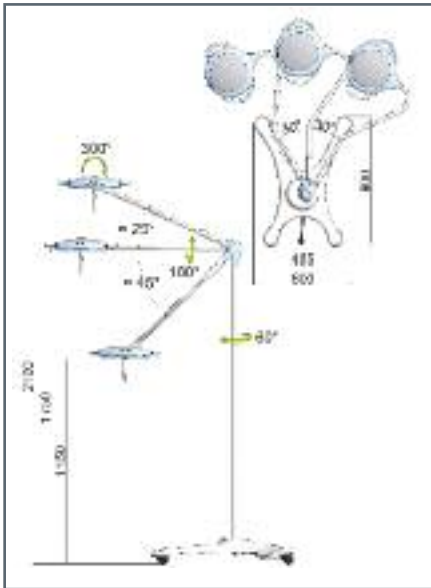

PENTALED 12+12

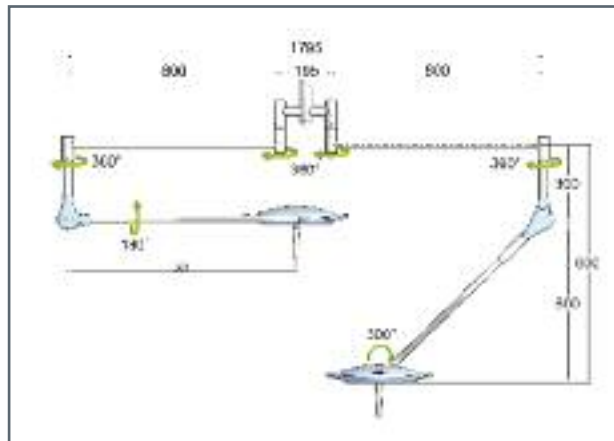

PENTALED 12 WALL

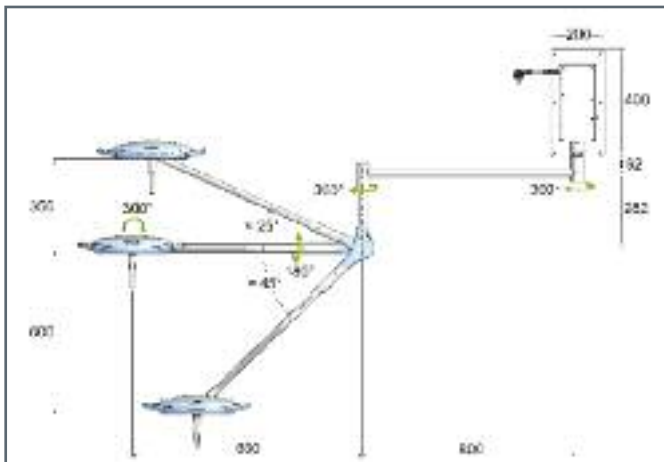



RIMSA AND THE ENVIRONMENT

The respect and the protection of the environment have always been a priority to RIMSA.

RIMSA has promoted renewable non-polluting energy sources, equipping each plant with photovoltaic systems which produce 100% requirements for constructing its devices. This renewable energy, obtained from the sun without emissions of CO₂ in the environment, contributes towards the reduction of air pollution.

RIMSA: "The photo shows the first RIMSA plant equippe with photovoltaic panels".

RIMSA follows a thorough ecological policy for its products as well:

- it has been the first company in the world to apply the brand new LED technology to medical lamps as a valid substitute to the halogen tradition. The LED is ecological as it does not contain any mercury, toxic gases, filaments and fragile parts;
- using the LED together with the patented "indirect light" system reduces the electric consumption by a good 2/3 (about 66% less) compared to a conventional halogen lamp.



PENTALED 12 is therefore an ecological lamp all round:

- 50,000 hours lifetime of the LEDs thanks to the excellent dissipation of temperature
- only uses 1/3 of a halogen lamp
- 85% of recyclable materials. The upper part of the dome is made of anodized aluminum without epoxy powders
- solvent-free painting
- the package has a compact size and is made with 100% recyclable material
- the soft and rounded lines of the dome reduce the amount of cleansers for cleaning



RIMSA

Via Monterosa, 18/22 - 20038 Seregno (MB) - Italy - Tel. + 39 0362 325709 - Fax + 39 0362 328559

E-mail: info@rimsa.it - www.rimsa.it



EN 9001:2000



EN 13485:2003



RESEARCH & COMPONENTS



HAND-MADE IN ITALY